

Product Catalog 01/09-A

Tooling System

THICK TURRET

for machines without lubrication

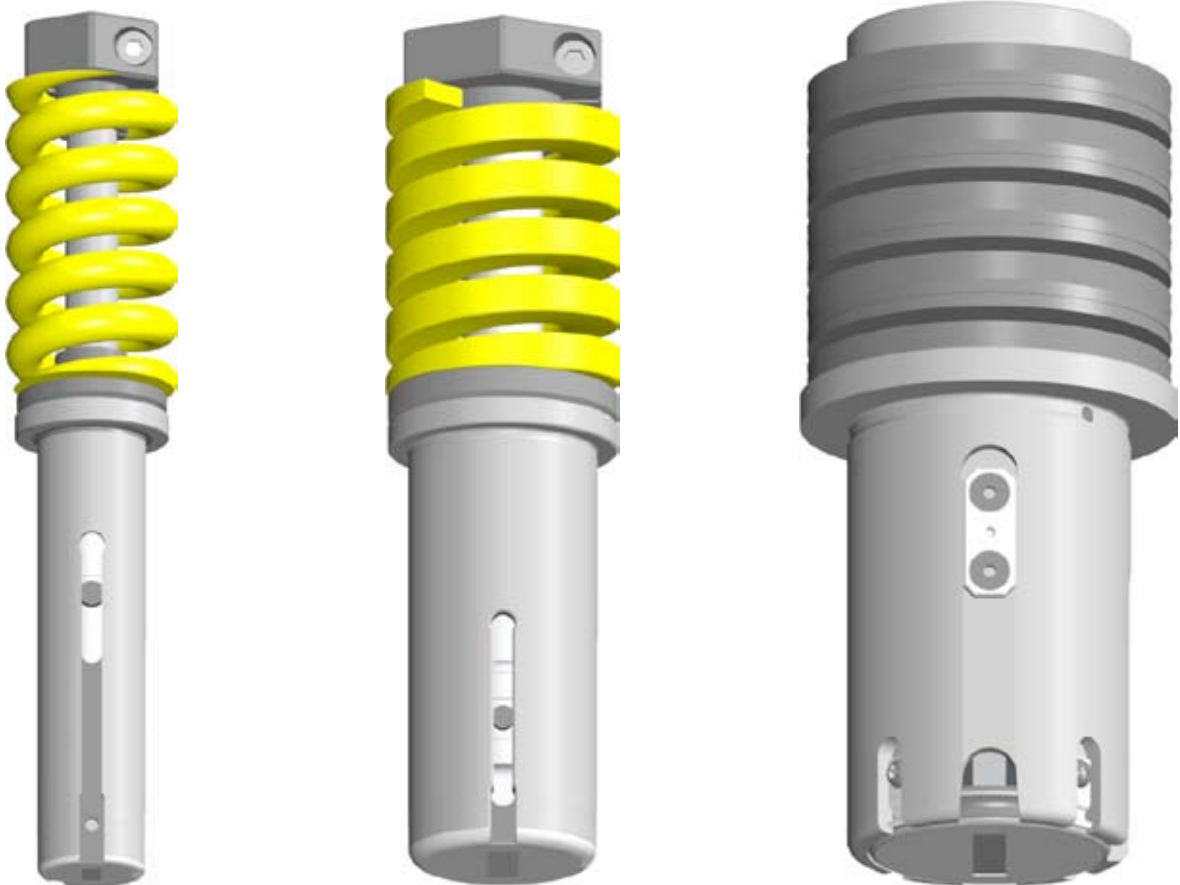

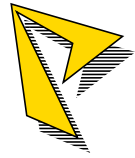

Pricelist 01/09-A

valid from 01.08.09

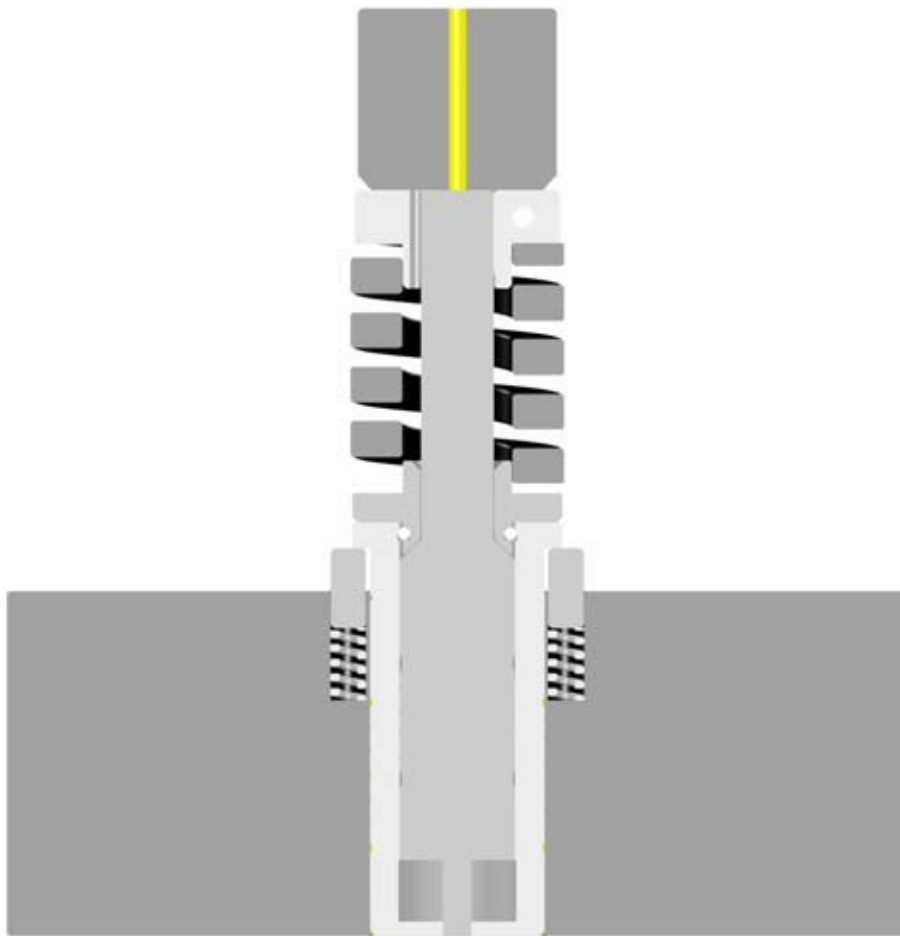

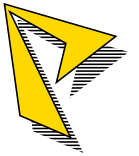

INDEX

Station A	PASS Standard	page	4 - 5
Station A	PASS Alpha	page	6 - 7
Station A	PASS Alpha-Compact	page	8 - 9
Station B	PASS Standard	page	10 - 11
Station B	PASS Alpha	page	12 - 13
Station B	PASS Alpha-Compact	page	14 - 15
Station C	PASS Standard	page	16 - 17
Station D	PASS Standard	page	18 - 19
Station E	PASS Standard	page	20 - 21
Special shapes		page	22 - 23

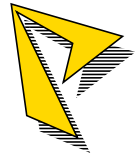

PASS Standard / Station A

Diameter up to 12,7 mm



Head unit

Hexagon head screw
for simply assembling of
the punch assembly

Spring
for sheet thickness up to 6 mm

2 mm length adjustment
by turning of the distance ring



Head unit

Canister
for sheet thickness up to 4 mm

Continuously and easy
length adjustment
in assembled status



Punch body

Metric-thread M12 x 1,25

Punch body made with premium HSS
(higher hit counts)

Alignment pin
for exact adjustment
(excludes round)



Punch guide

Surface-hardened and polished punch
guide for sheet thickness up to 6 mm

Keyway:

Round: 0°

Square: 0-45°

rect./oblong: 0-90-225°

asym. shapes: 0-90-180-270°

Tool shape integrated in guide



Punch guide

Surface-hardened and polished punch
guide for sheet thickness up to 6 mm

Keyway:

all shapes: 0-90°

Stripper

Interchangeable stripper plate

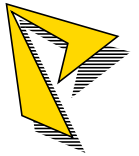

PASS Standard / Station A

Diameter up to 12,7 mm

	Part-no.	Price in €
Complete Punch Assembly		
Round	4012A01	
Square	4012A02	
Rectangle	4012A03	
Oblong	4012A04	
*O.D. Ground Special Shapes	4012A0G	
* EDM required Special Shapes	4012A0E	
Head unit (head screw, spring, distance ring)		
for all shapes	4092A01	
Punch body		
Round	4022A01	
Square	4022A02	
Rectangle	4022A03	
Oblong	4022A04	
*O.D. Ground Special Shapes	4022A0G	
* EDM required Special Shapes	4022A0E	
Punch guide		
Round	4032A01	
Square	4032A02	
Rectangle	4032A03	
Oblong	4032A04	
*O.D. Ground Special Shapes	4032A0G	
* EDM required Special Shapes	4032A0E	
Die		
Round	4052A01	
Square	4052A02	
Rectangle	4052A03	
Oblong	4052A04	
*O.D. Ground Special Shapes	4052A0G	
* EDM required Special Shapes	4052A0E	



Spare parts:		
Head screw	4092A31	
Spring	4092A11	
Distance ring	4092A21	
O-Ring (in punch guide)	4092A51	
PU-ejector Ø 3x6 (in punch)	4092P03	
PU-ejector Ø 6x10 (in punch)	4092P06	

Additional costs for punch:	
TICN coating	
T-MAX coating	
WT-shear	
DOWT-shear	
2 PT-shear	
4 PT-shear	

Compensating shims for punch:		
piece (2 mm)	499A4S2	

Additional costs for punch guide:	
additional keyway	

Compensating shims for die:		
1x0,4 mm/1x0,8 mm/1x1,2 mm	499A1M1	

Additional costs for die:	
reinforced die	

* see page 22-23

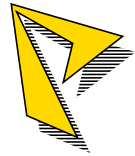

PASS Alpha / Station A

Diameter up to 12,7 mm



Head unit

Hexagon head screw
for simply assembling of
the punch assembly

Spring
for sheet thickness up to 6 mm

2 mm length adjustment
by turning of the distance ring



Head unit

Canister
for sheet thickness up to 4 mm

Continuously and easy
length adjustment
in assembled status



Punch body

Metric-thread M12 x 1,25

Punch body made with premium HSS
(higher hit counts)

Alignment pin
for exact adjustment
(excludes round)



Punch guide

Surface-hardened and polished punch
guide for sheet thickness up to 6 mm

Keyway:
Round: 0°
Square: 0-45°
rect./oblong: 0-90-225°
asym. shapes: 0-90-180-270°

Tool shape integrated in guide



Punch guide

Surface-hardened and polished punch
guide for sheet thickness up to 6 mm

Keyway:
all shapes: 0-90°

Stripper

Interchangeable stripper plate

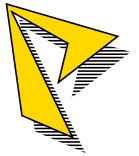

PASS Alpha / Station A

Diameter up to 12,7 mm

	Part-no.	Price in €
Complete Punch Assembly		
Round	4013A01	
Square	4013A02	
Rectangle	4013A03	
Oblong	4013A04	
*O.D. Ground Special Shapes	4013A0G	
* EDM required Special Shapes	4013A0E	
Head unit		
for all shapes	4093A01	
Punch body		
Round	4023A01	
Square	4023A02	
Rectangle	4023A03	
Oblong	4023A04	
*O.D. Ground Special Shapes	4023A0G	
* EDM required Special Shapes	4023A0E	
Punch guide		
for all shapes	4033A05	
Stripper		
Round	4043A01	
Square	4043A02	
Rectangle	4043A03	
Oblong	4043A04	
*O.D. Ground Special Shapes	4043A0G	
* EDM required Special Shapes	4043A0E	
Die		
Round	4052A01	
Square	4052A02	
Rectangle	4052A03	
Oblong	4052A04	
*O.D. Ground Special Shapes	4052A0G	
* EDM required Special Shapes	4052A0E	

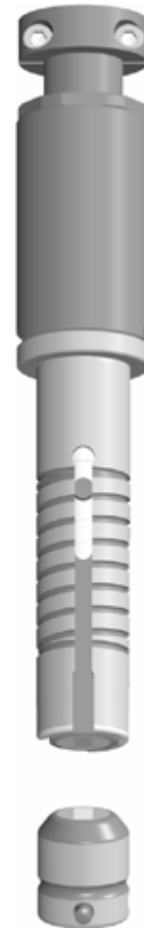

Spare parts:		
O-Ring (in punch guide)	4092A51	
PU-ejector Ø 3x6 (in punch)	4092P03	
PU-ejector Ø 6x10 (in punch)	4092P06	

Additional costs for punch:	
TICN coating	
T-MAX coating	
WT-shear	
DOWT-shear	
2 PT-shear	
4 PT-shear	

Compensating shims for punch:	
	not necessary

Additional costs for punch guide:	
	additional keyway

Compensating shims for die:	
1x0,4 mm/1x0,8 mm/1x1,2 mm	499A1M1

Additional costs for die:	
	reinforced die

* see page 22-23

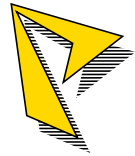

PASS Alpha-Compact / Station A

Diameter up to 12,7 mm



Head unit

Hexagon head screw
for simply assembling of
the punch assembly

Spring
for sheet thickness up to 6 mm

2 mm length adjustment
by turning of the distance ring



Head unit

Canister
for sheet thickness up to 4 mm

Continuously and easy
length adjustment
in assembled status



Punch body

Metric-thread M12 x 1,25

Punch body made with premium HSS
(higher hit counts)

Alignment pin
for exact adjustment
(excludes round)



Punch guide

Surface-hardened and polished punch
guide for sheet thickness up to 6 mm

Keyway:

Round: 0°

Square: 0-45°

rect./oblong: 0-90-225°

asym. shapes: 0-90-180-270°

Tool shape integrated in guide



Punch guide

Surface-hardened and polished punch
guide for sheet thickness up to 6 mm

Keyway:

all shapes: 0-90°

Stripper

Interchangeable stripper plate

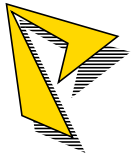

PASS Alpha-Compact / Station A

Diameter up to 12,7 mm

	Part-no.	Price in €
Complete Punch Assembly		
Round	4017A01	
Square	4017A02	
Rectangle	4017A03	
Oblong	4017A04	
*O.D. Ground Special Shapes	4017A0G	
* EDM required Special Shapes	4017A0E	
Head unit		
for all shapes	4093A01	
Punch body		
Round	4023A01	
Square	4023A02	
Rectangle	4023A03	
Oblong	4023A04	
*O.D. Ground Special Shapes	4023A0G	
* EDM required Special Shapes	4023A0E	
Punch guide		
Round	4032A01	
Square	4032A02	
Rectangle	4032A03	
Oblong	4032A04	
*O.D. Ground Special Shapes	4032A0G	
* EDM required Special Shapes	4032A0E	
Die		
Round	4052A01	
Square	4052A02	
Rectangle	4052A03	
Oblong	4052A04	
*O.D. Ground Special Shapes	4052A0G	
* EDM required Special Shapes	4052A0E	

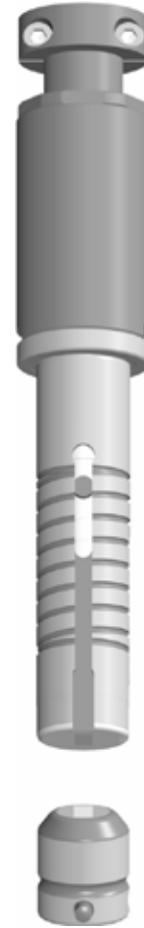

Spare parts:		
O-Ring (in punch guide)	4092A51	
PU-ejector Ø 3x6 (in punch)	4092P03	
PU-ejector Ø 6x10 (in punch)	4092P06	

Additional costs for punch:	
TICN coating	
T-MAX coating	
WT-shear	
DOWT-shear	
2 PT-shear	
4 PT-shear	

Compensating shims for punch:	
	not necessary

Additional costs for punch guide:	
	additional keyway

Compensating shims for die:	
1x0,4 mm/1x0,8 mm/1x1,2 mm	499A1M1

Additional costs for die:	
	reinforced die

* see page 22-23

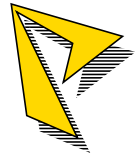

PASS Standard / Station B

Diameter up to 31,7 mm



Head unit

Hexagon head screw
for simply assembling of
the punch assembly

Spring
for sheet thickness up to 6 mm

2 mm length adjustment
by turning of the distance ring



Head unit

Canister
for sheet thickness up to 4 mm

Continuously and easy
length adjustment
in assembled status



Punch body

Metric-thread M20 x 1,5

Punch body made with premium HSS
(higher hit counts)

Alignment pin
for exact adjustment
(excludes round)



Punch guide

Surface-hardened and polished punch
guide for sheet thickness up to 6 mm

Keyway:

Round: 0°

Square: 0-45°

rect./oblong: 0-45-90-135°

asym. shapes: 0-90-180-270°

Tool shape integrated in guide



Punch guide

Surface-hardened and polished punch
guide for sheet thickness up to 6 mm

Keyway:

all shapes: 0-45-90-180-270°

Stripper

Interchangeable stripper plate

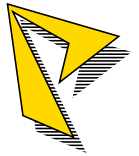

PASS Standard / Station B

Diameter up to 31,7 mm

	Part-no.	Price in €
Complete Punch Assembly		
Round	4012B01	
Square	4012B02	
Rectangle	4012B03	
Oblong	4012B04	
*O.D. Ground Special Shapes	4012B0G	
* EDM required Special Shapes	4012B0E	
Head unit (head screw, spring, distance ring)		
for all shapes	4092B01	
Punch body		
Round	4022B01	
Square	4022B02	
Rectangle	4022B03	
Oblong	4022B04	
*O.D. Ground Special Shapes	4022B0G	
* EDM required Special Shapes	4022B0E	
Punch guide		
Round	4032B01	
Square	4032B02	
Rectangle	4032B03	
Oblong	4032B04	
*O.D. Ground Special Shapes	4032B0G	
* EDM required Special Shapes	4032B0E	
Die		
Round	4052B01	
Square	4052B02	
Rectangle	4052B03	
Oblong	4052B04	
*O.D. Ground Special Shapes	4052B0G	
* EDM required Special Shapes	4052B0E	



Spare parts:		
Head screw	4092B31	
Spring	4092B11	
Distance ring	4092B21	
O-Ring (in Punch guide)	4092B51	
PU-ejector Ø 3x6 (in punch)	4092P03	
PU-ejector Ø 6x10 (in punch)	4092P06	

Additional costs for punch:	
TICN coating	
T-MAX coating	
WT-shear	
DOWT-shear	
2 PT-shear	
4 PT-shear	

Compensating shims for punch:	
piece (2 mm)	499B4S2

Additional costs for punch guide:	
additional keyway	

Compensating shims for die:	
1x0,4 mm/1x0,8 mm/1x1,2 mm	499B1M1

Additional costs for die:	
reinforced die	

* see page 22-23

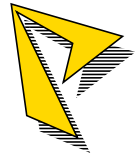

PASS Alpha / Station B

Diameter up to 31,7 mm



Head unit

Hexagon head screw
for simply assembling of
the punch assembly

Spring
for sheet thickness up to 6 mm

2 mm length adjustment
by turning of the distance ring



Head unit

Canister
for sheet thickness up to 4 mm

Continuously and easy
length adjustment
in assembled status



Punch body

Metric-thread M20 x 1,5

Punch body made with premium HSS
(higher hit counts)

Alignment pin
for exact adjustment
(excludes round)



Punch guide

Surface-hardened and polished punch
guide for sheet thickness up to 6 mm

Keyway:

Round: 0°

Square: 0-45°

rect./oblong: 0-45-90-135°

asym. shapes: 0-90-180-270°

Tool shape integrated in guide



Punch guide

Surface-hardened and polished punch
guide for sheet thickness up to 6 mm

Keyway:

all shapes: 0-45-90-180-270°

Stripper

Interchangeable stripper plate

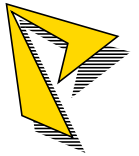

PASS Alpha / Station B

Diameter up to 31,7 mm

	Part-no.	Price in €
Complete Punch Assembly		
Round	4013B01	
Square	4013B02	
Rectangle	4013B03	
Oblong	4013B04	
*O.D. Ground Special Shapes	4013B0G	
* EDM required Special Shapes	4013B0E	
Head unit		
for all shapes	4093B01	
Punch body		
Round	4023B01	
Square	4023B02	
Rectangle	4023B03	
Oblong	4023B04	
*O.D. Ground Special Shapes	4023B0G	
* EDM required Special Shapes	4023B0E	
Punch guide		
for all shapes	4033B05	
Stripper		
Round	4043B01	
Square	4043B02	
Rectangle	4043B03	
Oblong	4043B04	
*O.D. Ground Special Shapes	4043B0G	
* EDM required Special Shapes	4043B0E	
Die		
Round	4052B01	
Square	4052B02	
Rectangle	4052B03	
Oblong	4052B04	
*O.D. Ground Special Shapes	4052B0G	
* EDM required Special Shapes	4052B0E	



Spare parts:		
O-Ring (in punch guide)	4092B51	
PU-ejector Ø 3x6 (in punch)	4092P03	
PU-ejector Ø 6x10 (in punch)	4092P06	

Additional costs for punch:	
TICN coating	
T-MAX coating	
WT-shear	
DOWT-shear	
2 PT-shear	
4 PT-shear	

Compensating shims for punch:	
	not necessary

Additional costs for punch guide:	
	additional keyway

Compensating shims for die:	
1x0,4 mm/1x0,8 mm/1x1,2 mm	499B1M1

Additional costs for die:	
	reinforced die

* see page 22-23

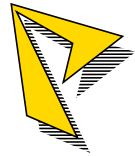

PASS Alpha-Compact / Station B

Diameter up to 31,7 mm



Head unit

Hexagon head screw
for simply assembling of
the punch assembly

Spring
for sheet thickness up to 6 mm

2 mm length adjustment
by turning of the distance ring



Head unit

Canister
for sheet thickness up to 4 mm

Continuously and easy
length adjustment
in assembled status



Punch body

Metric-thread M20 x 1,5

Punch body made with premium HSS
(higher hit counts)

Alignment pin
for exact adjustment
(excludes round)



Punch guide

Surface-hardened and polished punch
guide for sheet thickness up to 6 mm

Keyway:

Round: 0°

Square: 0-45°

rect./oblong: 0-45-90-135°

asym. shapes: 0-90-180-270°

Tool shape integrated in guide



Punch guide

Surface-hardened and polished punch
guide for sheet thickness up to 6 mm

Keyway:

all shapes: 0-45-90-180-270°

Stripper

Interchangeable stripper plate

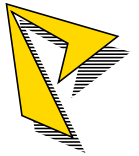

PASS Alpha-Compact / Station B

Diameter up to 31,7 mm

	Part-no.	Price in €
Complete Punch Assembly		
Round	4017B01	
Square	4017B02	
Rectangle	4017B03	
Oblong	4017B04	
*O.D. Ground Special Shapes	4017B0G	
* EDM required Special Shapes	4017B0E	
Head unit		
for all shapes	4093B01	
Punch body		
Round	4023B01	
Square	4023B02	
Rectangle	4023B03	
Oblong	4023B04	
*O.D. Ground Special Shapes	4023B0G	
* EDM required Special Shapes	4023B0E	
Punch guide		
Round	4032B01	
Square	4032B02	
Rectangle	4032B03	
Oblong	4032B04	
*O.D. Ground Special Shapes	4032B0G	
* EDM required Special Shapes	4032B0E	
Die		
Round	4052B01	
Square	4052B02	
Rectangle	4052B03	
Oblong	4052B04	
*O.D. Ground Special Shapes	4052B0G	
* EDM required Special Shapes	4052B0E	



Spare parts:		
O-Ring (in punch guide)	4092B51	
PU-ejector Ø 3x6 (in punch)	4092P03	
PU-ejector Ø 6x10 (in punch)	4092P06	

Additional costs for punch:	
TICN coating	
T-MAX coating	
WT-shear	
DOWT-shear	
2 PT-shear	
4 PT-shear	

Compensating shims for punch:	
	not necessary

Additional costs for punch guide:	
	additional keyway

Compensating shims for die:	
1x0,4 mm/1x0,8 mm/1x1,2 mm	499B1M1

Additional costs for die:	
	reinforced die

* see page 22-23

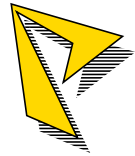

PASS Standard / Station C

Diameter up to 50,8 mm



Guide Assembly

Screw M12

Springs for sheet thickness up to 6 mm

3 mm length adjustment
by using compensating shims

Keyway: 0-90°

Surface-hardened and polished punch guide
for sheet thickness up to 6 mm

Clamping-screws to fix the strippers



Punch body

Thread M12

Punch body made with premium HSS
(higher hit counts)



Stripper

Interchangeable stripper plate

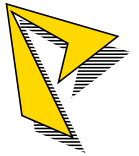

PASS Standard / Station C

Diameter up to 50,8 mm

	Part-no.	Price in €
Guide Assembly		
for all shapes	499C01	

Punch body		
Round	4022C01	
Square	4022C02	
Rectangle	4022C03	
Oblong	4022C04	
*O.D. Ground Special Shapes	4022C0G	
* EDM required Special Shapes	4022C0E	

Stripper		
Round	4032C01	
Square	4032C02	
Rectangle	4032C03	
Oblong	4032C04	
*O.D. Ground Special Shapes	4032C0G	
* EDM required Special Shapes	4032C0E	

Die		
Round	4052C01	
Square	4052C02	
Rectangle	4052C03	
Oblong	4052C04	
*O.D. Ground Special Shapes	4052C0G	
* EDM required Special Shapes	4052C0E	

Spare parts:		
PU-ejector Ø 3x6 (in punch)	4092P03	
PU-ejector Ø 6x10 (in punch)	4092P06	
Set clamping-springs with screws	499C71	
Guiding key with screws	499C63	

Compensating shims for punch:		
1x0,4 mm/1x0,8 mm/1x1,2 mm	499C1S1	

Compensating shims for die:		
1x0,4 mm/1x0,8 mm/1x1,2 mm	499C2M1	



Additional costs for punch:	
TICN coating	
T-MAX coating	
WT-shear	
DOWT-shear	
2 PT-shear	
4 PT-shear	

additional keyway

Additional costs for punch guide:	
additional keyway	

* see page 22-23

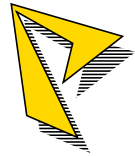

PASS Standard / Station D

Diameter up to 88,9 mm



Guide Assembly

Screw M12

Springs for sheet thickness up to 6 mm

3 mm length adjustment
by using compensating shims

Keyway: 0-90°

Surface-hardened and polished punch guide
for sheet thickness up to 6 mm

Clamping-screws to fix the strippers

Punch body

Thread M12

Punch body made with premium HSS
(higher hit counts)

Stripper

Interchangeable stripper plate

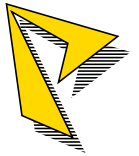

PASS Standard / Station D

Diameter up to 88,9 mm

	Part-no.	Price in €
Guide Assembly		
for all shapes	499D01	

Punch body		
Round	4022D01	
Square	4022D02	
Rectangle	4022D03	
Oblong	4022D04	
*O.D. Ground Special Shapes	4022D0G	
* EDM required Special Shapes	4022D0E	

Stripper		
Round	4032D01	
Square	4032D02	
Rectangle	4032D03	
Oblong	4032D04	
*O.D. Ground Special Shapes	4032D0G	
* EDM required Special Shapes	4032D0E	

Die		
Round	4052D01	
Square	4052D02	
Rectangle	4052D03	
Oblong	4052D04	
*O.D. Ground Special Shapes	4052D0G	
* EDM required Special Shapes	4052D0E	

Spare parts:		
PU-ejector Ø 3x6 (in punch)	4092P03	
PU-ejector Ø 6x10 (in punch)	4092P06	
Set clamping-springs with screws	499D71	
Guiding key with screws	499D63	

Compensating shims for punch:		
1x0,4 mm/1x0,8 mm/1x1,2 mm	499D3S1	

Compensating shims for die:		
1x0,4 mm/1x0,8 mm/1x1,2 mm	499D2M1	



Additional costs for punch:	
TICN coating	
T-MAX coating	
WT-shear	
DOWT-shear	
2 PT-shear	
4 PT-shear	
additional keyway	

Additional costs for punch guide:	
additional keyway	

* see page 22-23

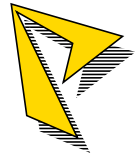

PASS Standard / Station E

Diameter up to 114,3 mm



Guide Assembly

Screw M12

Springs for sheet thickness up to 6 mm

3 mm length adjustment
by using compensating shims

Keyway: 0-90°

Surface-hardened and polished punch guide
for sheet thickness up to 6 mm

Clamping-screws to fix the strippers

Punch body

Thread M12

Punch body made with premium HSS
(higher hit counts)

Stripper

Interchangeable stripper plate

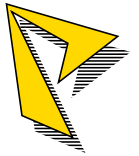

PASS Standard / Station E

Diameter up to 114,3 mm

	Part-no.	Price in €
Guide Assembly		

for all shapes	499E01	
----------------	--------	--

Punch body		
Round	4022E01	
Square	4022E02	
Rectangle	4022E03	
Oblong	4022E04	
*O.D. Ground Special Shapes	4022E0G	
* EDM required Special Shapes	4022E0E	

Stripper		
Round	4032E01	
Square	4032E02	
Rectangle	4032E03	
Oblong	4032E04	
*O.D. Ground Special Shapes	4032E0G	
* EDM required Special Shapes	4032E0E	

Die		
Round	4052E01	
Square	4052E02	
Rectangle	4052E03	
Oblong	4052E04	
*O.D. Ground Special Shapes	4052E0G	
* EDM required Special Shapes	4052E0E	

Spare parts:		
PU-ejector Ø 3x6 (in punch)	4092P03	
PU-ejector Ø 6x10 (in punch)	4092P06	
Set clamping-springs with screws	499E71	
Guiding key with screws	499E63	

Compensating shims for punch:		
1x0,4 mm/1x0,8 mm/1x1,2 mm	499E3S1	

Compensating shims for die:		
1x0,4 mm/1x0,8 mm/1x1,2 mm	499E2M1	



Additional costs for punch:	
TICN coating	
T-MAX coating	
WT-shear	
DOWT-shear	
2 PT-shear	
4 PT-shear	
additional keyway	

Additional costs for punch guide:	
additional keyway	

* see page 22-23

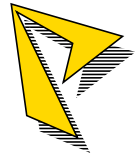

O.D. Ground Special shapes

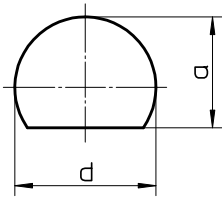
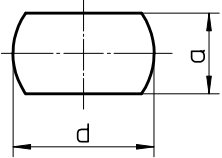
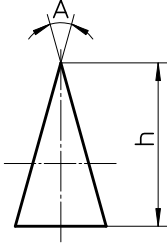
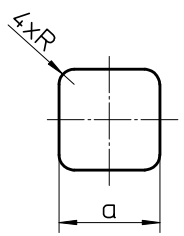
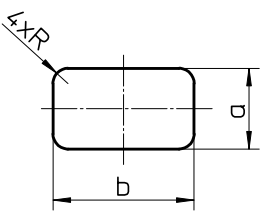
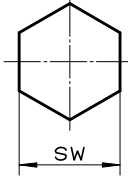
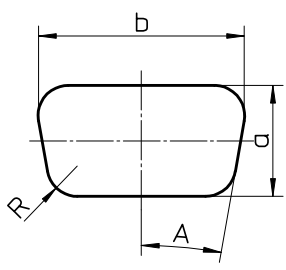
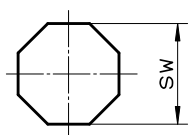
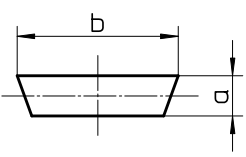
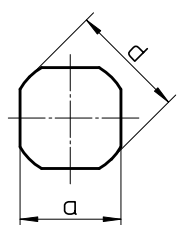
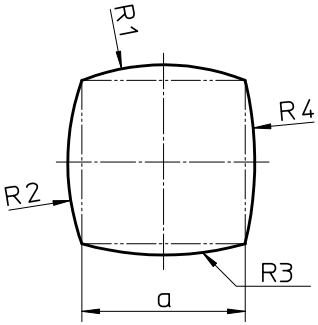
 <p>G01</p>	 <p>G02</p>	 <p>G03</p>
 <p>G04</p>	 <p>G05</p>	 <p>G06</p>
 <p>G07</p>	 <p>G08</p>	 <p>G09</p>
 <p>G10</p>	 <p>G11</p>	<p><i>Please inquire for other shapes not indicated in this page!</i></p>

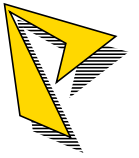

EDM required Special shapes

<p>E01</p>	<p>E02</p>	<p>E03</p>
<p>E04</p>	<p>E05</p>	<p>E06</p>
<p>E07</p>	<p>E08</p>	<p>E09</p>
<p>E10</p>	<p>E11</p>	<p><i>Please inquire for other shapes not indicated in this page!</i></p>