

Product Catalog 01/2009-A

Tooling System

FINN-POWER/LVD Multitool

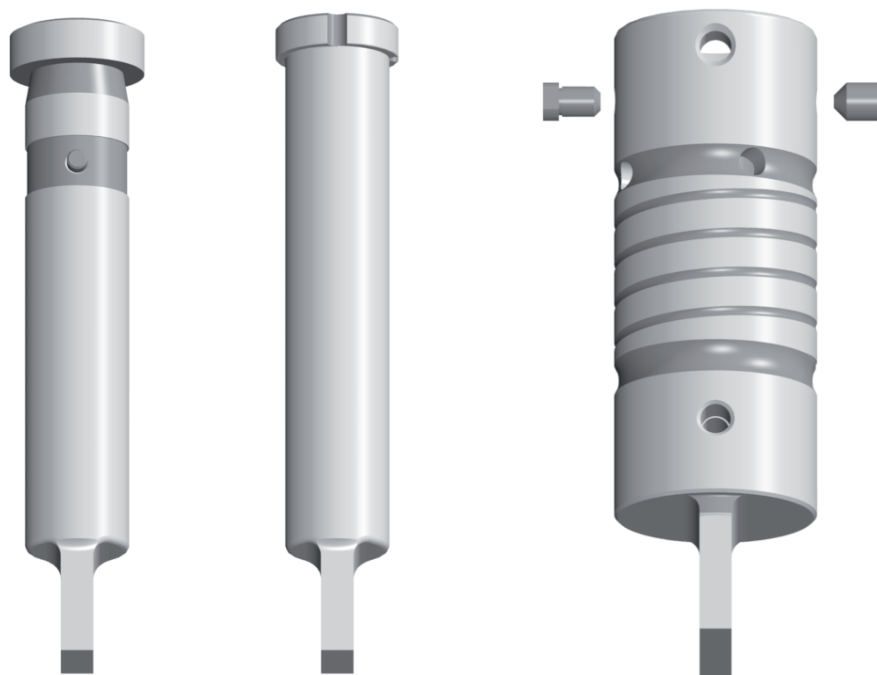



System

FINN-POWER/LVD

MT24Ri-8

MT24i-8

MT20i-8

	Pos.-no.	Part-no.	Price in €
Punch*			
Round	1	413111	
Square	1	413112	
Rectangular	1	413113	
Oblong	1	413114	
*O.D. Ground Special Shapes	1	41311G	
* EDM required Special Shapes	1	41311E	
Stripper			
Round	2	415111	
Square	2	415112	
Rectangular	2	415113	
Oblong	2	415114	
*O.D. Ground Special Shapes	2	41511G	
* EDM required Special Shapes	2	41511E	
Die			
Round	3	414111	
Square	3+4	414112	
Rectangular	3+4	414113	
Oblong	3+4	414114	
*O.D. Ground Special Shapes	3+4	41411G	
* EDM required Special Shapes	3+4	41411E	

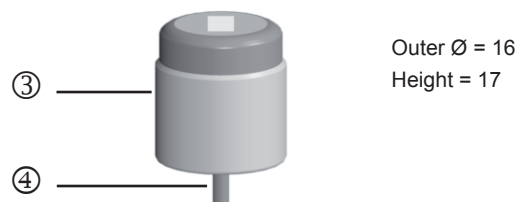
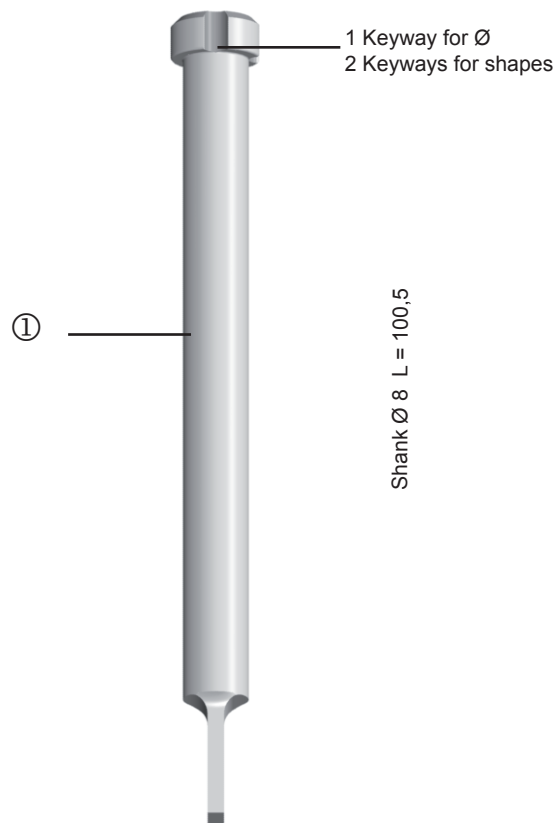

Additional tool costs:	
Punch	TICN Coating T-MAX Coating WT-Shear DOWT-Shear 2PT-Shear 4PT-Shear
Die	reinforced version

*suitable up to s = 6 mm



FINN-POWER/LVD MT8Ri1-16

Pos.-no. Part-no. Price in €

Punch*

Round	1	413051
Square	1+4	413052
Rectangular	1+4	413053
Oblong	1+4	413054
*O.D. Ground Special Shapes	1+4	41305G
* EDM required Special Shapes	1+4	41305E

Stripper

Round	2	415051
Square	2	415052
Rectangular	2	415053
Oblong	2	415054
*O.D. Ground Special Shapes	2	41505G
* EDM required Special Shapes	2	41505E

Die

Round	3	414051
Square	3+5	414052
Rectangular	3+5	414053
Oblong	3+5	414054
*O.D. Ground Special Shapes	3+5	41405G
* EDM required Special Shapes	3+5	41405E

Version 1

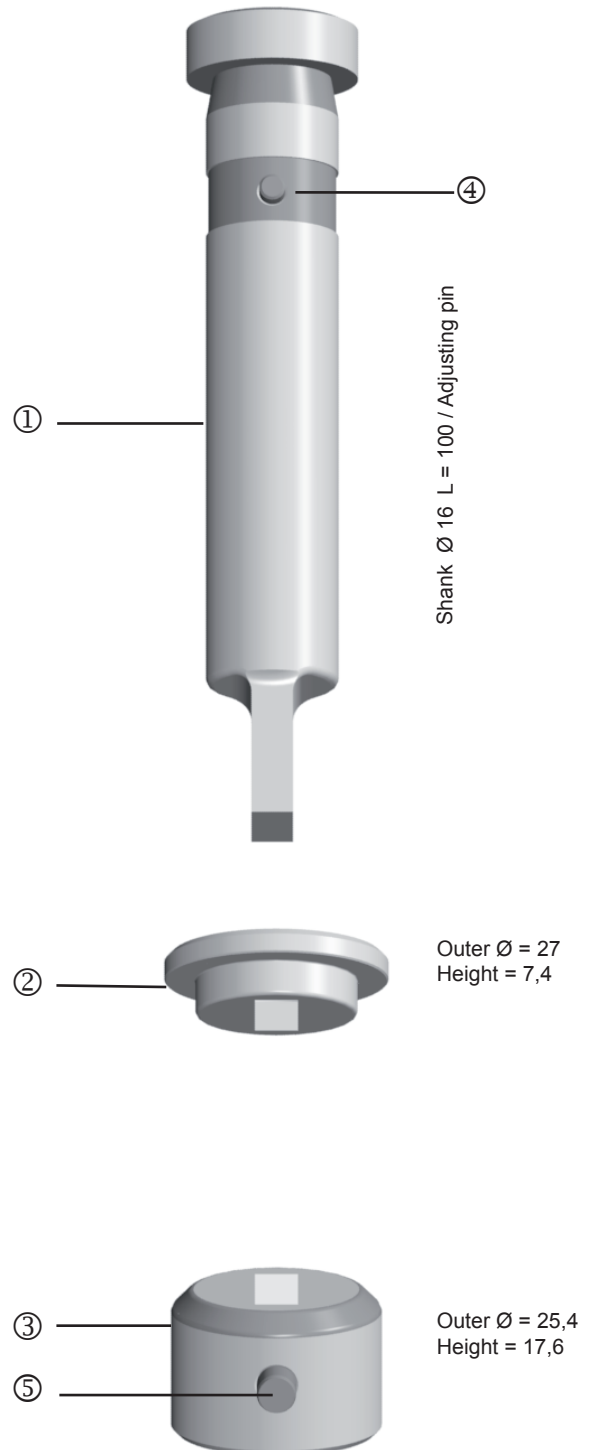

Additional tool costs:

Punch	TICN Coating
	T-MAX Coating
	WT-Shear
	DOWT-Shear
	2PT-Shear
	4PT-Shear
Die	reinforced version

*suitable up to s = 6 mm



FINN-POWER/LVD MT8Ri2-16

Pos.-no. Part-no. Price in €

Punch*

Round	1	413151
Square	1	413152
Rectangular	1	413153
Oblong	1	413154
*O.D. Ground Special Shapes	1	41315G
* EDM required Special Shapes	1	41315E

Stripper

Round	2	415151
Square	2	415152
Rectangular	2	415153
Oblong	2	415154
*O.D. Ground Special Shapes	2	41515G
* EDM required Special Shapes	2	41515E

Die

Round	3	414151
Square	3+4	414152
Rectangular	3+4	414153
Oblong	3+4	414154
*O.D. Ground Special Shapes	3+4	41415G
* EDM required Special Shapes	3+4	41415E

Additional tool costs:

Punch	TICN Coating
	T-MAX Coating
	WT-Shear
	DOWT-Shear
	2PT-Shear
	4PT-Shear
Die	reinforced version

*suitable up to s = 6 mm

Version 2

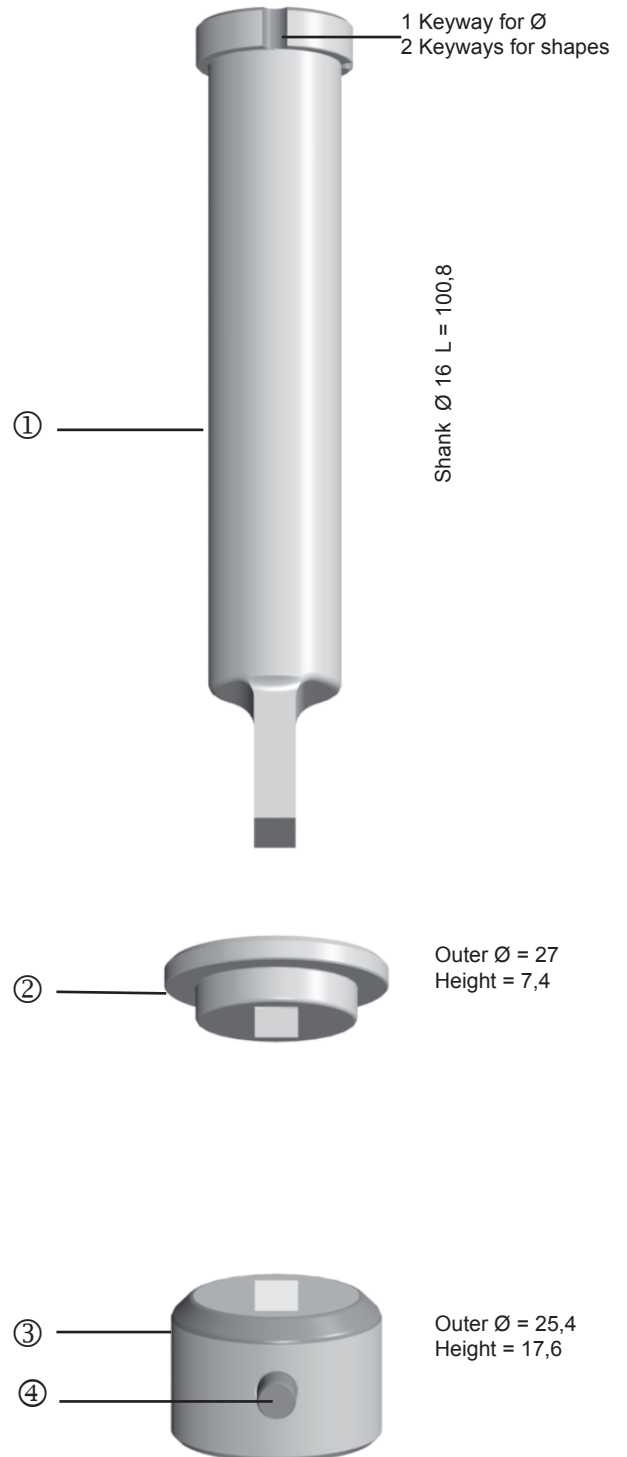



FINN-POWER/LVD

MT3Ri-31,75

MT3i-31,75

	Pos.-no.	Part-no.	Price in €
Punch*			
Round	1+4+5	413071	
Square	1+4+5	413072	
Rectangular	1+4+5	413073	
Oblong	1+4+5	413074	
*O.D. Ground Special Shapes	1+4+5	41307G	
* EDM required Special Shapes	1+4+5	41307E	
Stripper			
Round	2	415071	
Square	2	415072	
Rectangular	2	415073	
Oblong	2	415074	
*O.D. Ground Special Shapes	2	41507G	
* EDM required Special Shapes	2	41507E	
Die			
Round	3	414071	
Square	3+6	414072	
Rectangular	3+6	414073	
Oblong	3+6	414074	
*O.D. Ground Special Shapes	3+6	41407G	
* EDM required Special Shapes	3+6	41407E	

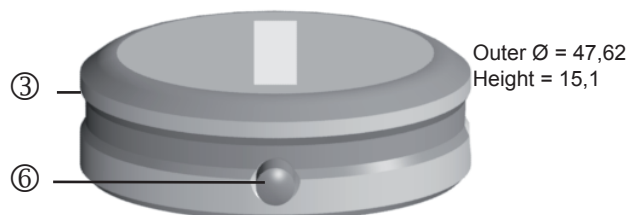
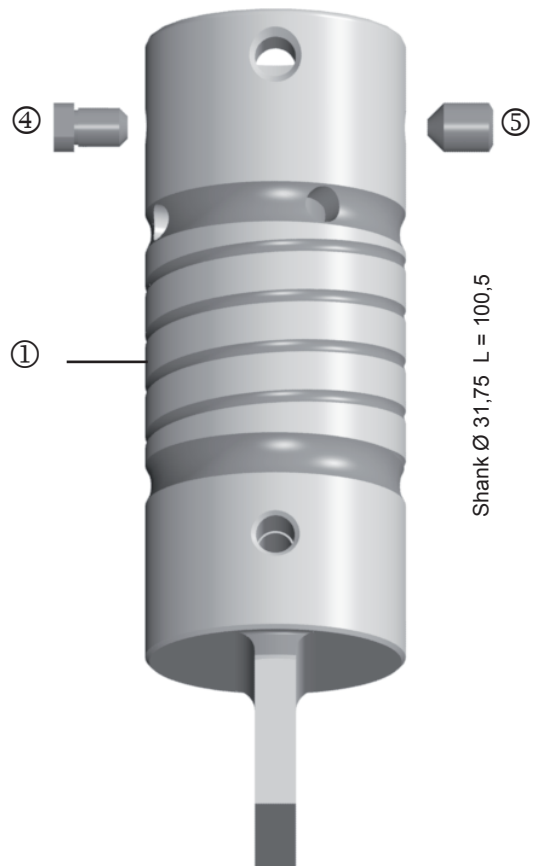

Additional tool costs:

Punch	TICN Coating
	T-MAX Coating
	WT-Shear
	DOWT-Shear
	2PT-Shear
	4PT-Shear
Die	reinforced version

*suitable up to s = 6 mm

System
FINN-POWER/LVD

MT24-8

MT12-8

MT20-8



	Pos.-no.	Part-no.	Price in €
Punch*			
Round	1	413121	
Square	1	413122	
Rectangular	1	413123	
Oblong	1	413124	
*O.D. Ground Special Shapes	1	41312G	
* EDM required Special Shapes	1	41312E	

Stripper			
Round	2	415121	
Square	2+4	415122	
Rectangular	2+4	415123	
Oblong	2+4	415124	
*O.D. Ground Special Shapes	2+4	41512G	
* EDM required Special Shapes	2+4	41512E	

Die			
Round	3	414121	
Square	3+5	414122	
Rectangular	3+5	414123	
Oblong	3+5	414124	
*O.D. Ground Special Shapes	3+5	41412G	
* EDM required Special Shapes	3+5	41412E	

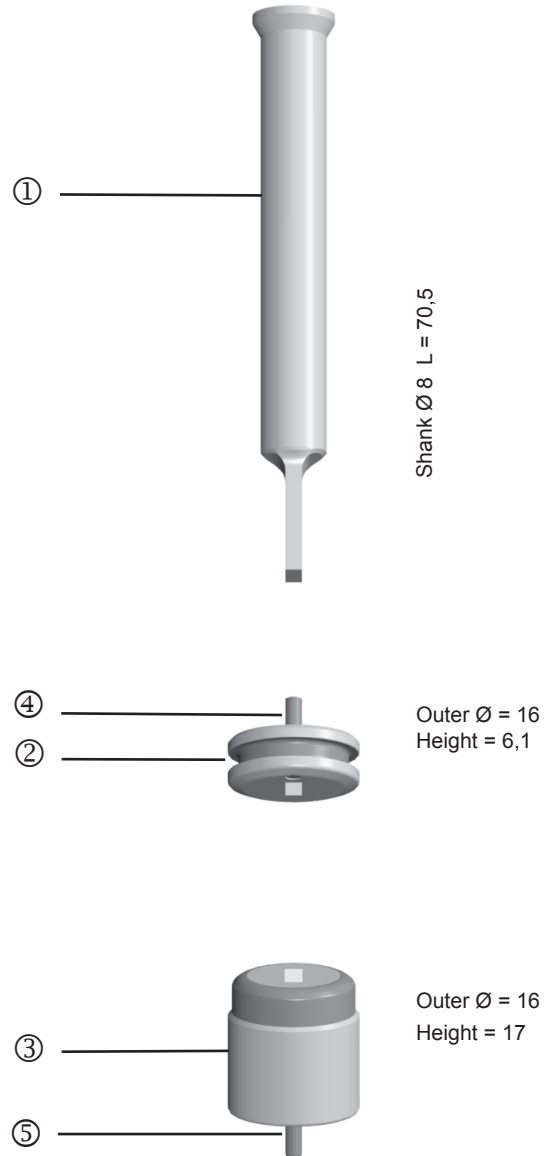

Additional tool costs:	
Punch	TICN Coating T-MAX Coating WT-Shear DOWT-Shear 2PT-Shear 4PT-Shear
Die	reinforced version

*suitable up to s = 4 mm



FINN-POWER/LVD

MT10-16

MT6-16

Pos.-no. Part-no. Price in €

Punch*

Round	1	413021
Square	1	413022
Rectangular	1	413023
Oblong	1	413024
*O.D. Ground Special Shapes	1	41302G
* EDM required Special Shapes	1	41302E

Stripper

Round	2	415021
Square	2+4	415022
Rectangular	2+4	415023
Oblong	2+4	415024
*O.D. Ground Special Shapes	2+4	41502G
* EDM required Special Shapes	2+4	41502E

Die

Round	3	414021
Square	3+5	414022
Rectangular	3+5	414023
Oblong	3+5	414024
*O.D. Ground Special Shapes	3+5	41402G
* EDM required Special Shapes	3+5	41402E

Additional tool costs:

Punch	TICN Coating
	T-MAX Coating
	WT-Shear
	DOWT-Shear
	2PT-Shear
	4PT-Shear
Die	reinforced version

*suitable up to s = 4 mm

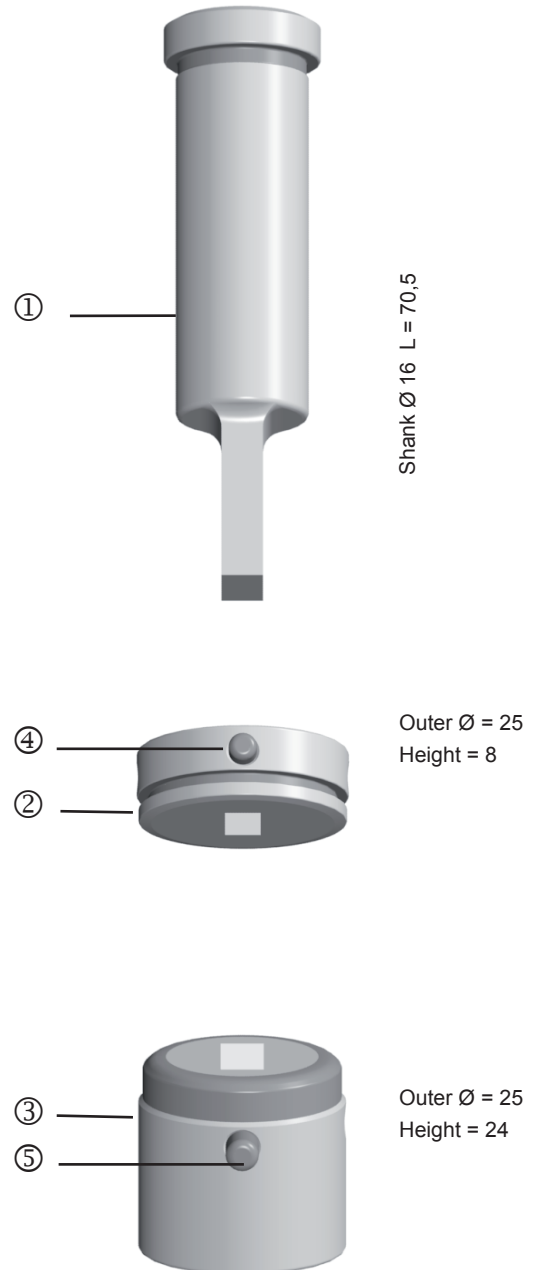



FINN-POWER/LVD MT8-24

Pos.-no. Part-no. Price in €

Punch*

Round	1	413131
Square	1	413132
Rectangular	1	413133
Oblong	1	413134
*O.D. Ground Special Shapes	1	41313G
* EDM required Special Shapes	1	41313E

Stripper

Round	2	415131
Square	2+4	415132
Rectangular	2+4	415133
Oblong	2+4	415134
*O.D. Ground Special Shapes	2+4	41513G
* EDM required Special Shapes	2+4	41513E

Die

Round	3	414131
Square	3+5	414132
Rectangular	3+5	414133
Oblong	3+5	414134
*O.D. Ground Special Shapes	3+5	41413G
* EDM required Special Shapes	3+5	41413E

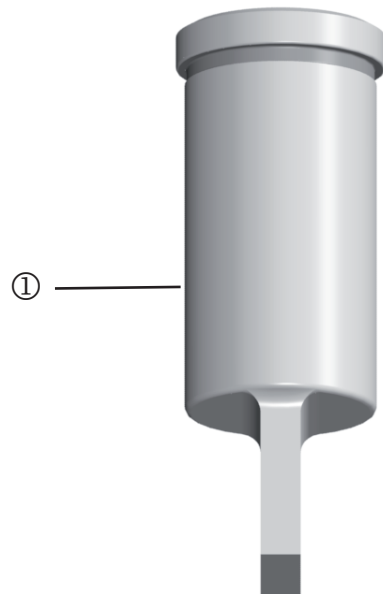

Shank Ø 24 L = 70,5

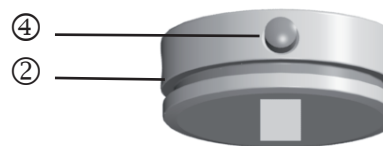

Outer Ø = 30
Height = 10,5

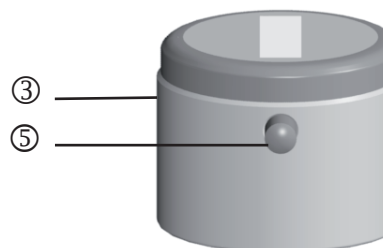

Outer Ø = 31
Height = 24

Additional tool costs:

Punch	TICN Coating
	T-MAX Coating
	WT-Shear
	DOWT-Shear
	2PT-Shear
	4PT-Shear
Die	reinforced version

*suitable up to s = 4 mm