

BRIDGE FORMING TOOL

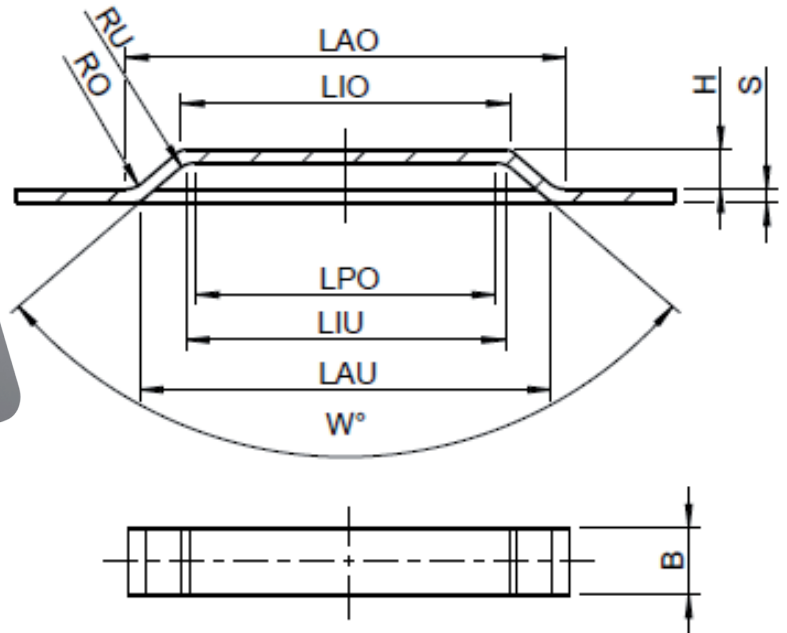

TRUMPF

THICK TURRET

SALVAGNINI

BASIC INFORMATION	
Material:	
Sheet thickness „s“:	
Machine:	
Size/station:	
Direction of forming:	upform <input type="checkbox"/>
	downform <input type="checkbox"/>
Customer information:	

TOOL INFORMATION IN MM	
LAU:	
LIU:	
LAO:	
LIO:	
LPO:	
H:	
W in °:	
B:	
RU:	
RO:	

Order_forms_Special_Tools 02/2017 Version 1.0